

AD-4212C-300

AD-4212C-3000

Production Weighing Unit

INSTRUCTION MANUAL



1WMPD4001992

© 2009 A&D Company, Limited. All rights reserved.

No part of this publication may be reproduced, transmitted, transcribed, or translated into any language in any form by any means without the written permission of A&D Company, Limited.

The contents of this manual and the specifications of the instrument covered by this manual are subject to change for improvement without notice.

Windows and Excel are registered trademarks of Microsoft Corporation.

CONTENTS

| | |
|---|----|
| 1. INTRODUCTION | 2 |
| 1.1. Features | 2 |
| 1.2. Compliance | 4 |
| 2. UNPACKING THE BALANCE..... | 5 |
| 2.1. Unpacking | 5 |
| 2.2. Installing the Balance | 7 |
| 3. PRECAUTIONS | 8 |
| 3.1. Before Use | 8 |
| 3.2. When Building Into a System | 9 |
| 3.3. During Use | 11 |
| 3.4. After Use | 11 |
| 3.5. Power Supply | 11 |
| 4. OPERATION OF WinCT-AD4212C | 12 |
| 4.1. Changing the Weighing Speed Using WinCT-AD4212C | 13 |
| 4.2. Calibration | 14 |
| 5. COMMUNICATION SPECIFICATIONS | 16 |
| 6. MAINTENANCE | 19 |
| 7. TROUBLESHOOTING | 19 |
| 7.1. Checking the Balance Performance and Environment | 19 |
| 7.2. Asking For Repair..... | 20 |
| 8. SPECIFICATIONS..... | 21 |
| 9. EXTERNAL DIMENSIONS | 22 |
| 10. OPTIONS | 23 |
| 11. TERMS/INDEX | 24 |

1. INTRODUCTION

This manual describes how the AD-4212C series balance works and how to get the most out of it in terms of performance.

Read this manual thoroughly before using the balance and keep it at hand for future reference.

1.1. Features

- A Weighing Unit, suitable for building into a production line system. The weighing unit is compact, with a width of 59 mm.
- High Resolution and High Response Speed

| Model | Weighing capacity | Minimum weighing value | Stabilization time *1 |
|---------------|-------------------|------------------------|--|
| AD-4212C-300 | 320 g | 0.001 g | 0.5 second (0 - 30g), 1.0 second (30 - 320g) |
| AD-4212C-3000 | 3200 g | 0.01 g | 0.5 second (0 - 30g), 1.0 second (30 - 3200g) |

*1 With **FAST** selected under good environment

- The AD-4212C series can output the weighing digital data directly. Therefore, the AD-4212C series (the weighing unit) can be connected to a personal computer or a PLC directly.
- Dust-protected and Protected Against Splashing Water (Complying with IP65). The AD-4212C series has a shock absorber under the weighing pan and can cope with movement in all directions, protecting the weighing unit from an actuator malfunction.
- Windows Communication Tools (WinCT-AD4212C), allows easy confirming of the weighing data by using a Windows-based personal computer.
Windows is a registered trademark of the Microsoft Corporation.
- When connected to an AD-8922A (optional), it can perform the taking of weighing data, re-zero and calibration manually. The AD-8922A can output data using BCD, comparator or analog out by selection of the option installed in the AD-8922A.
- When connected to an AD-8526 (optional), it can convert RS-232C output data to a LAN.

Example 1 (Connecting to a personal computer or an AD-8922A)

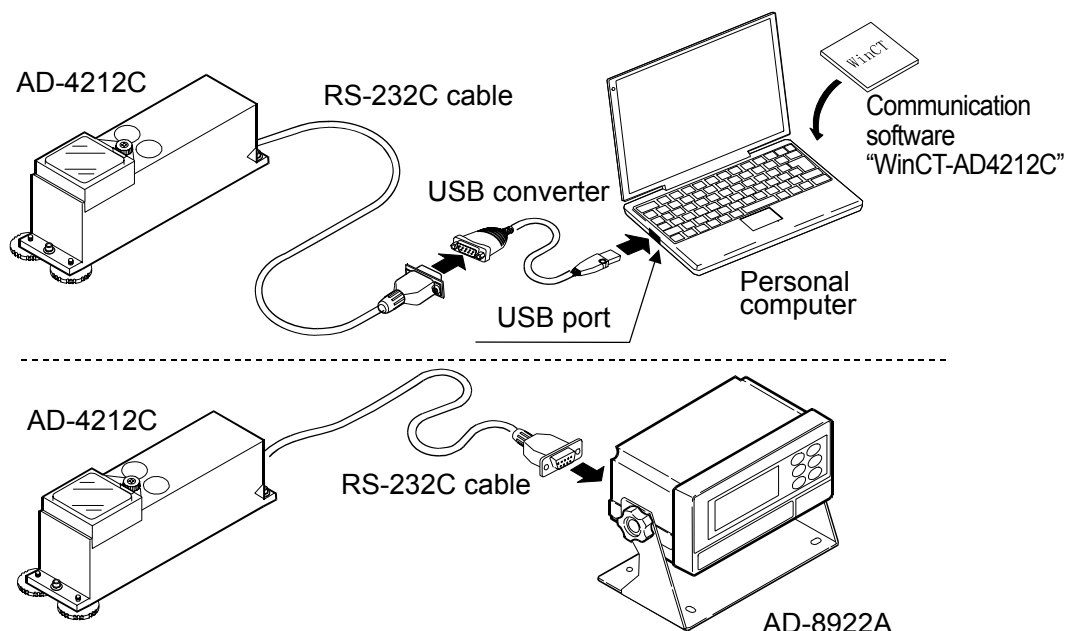

Example 2 (Connecting to a PLC)

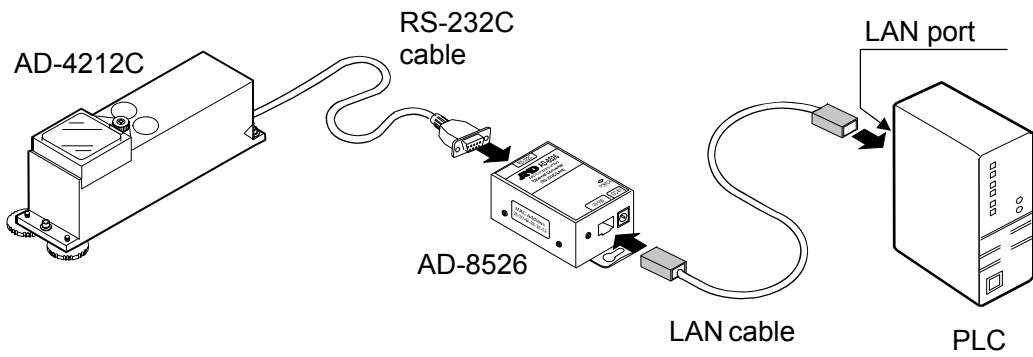
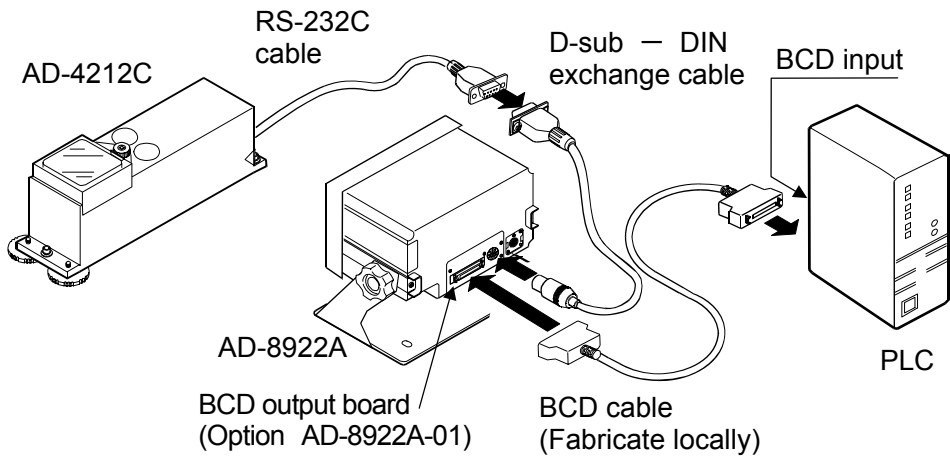
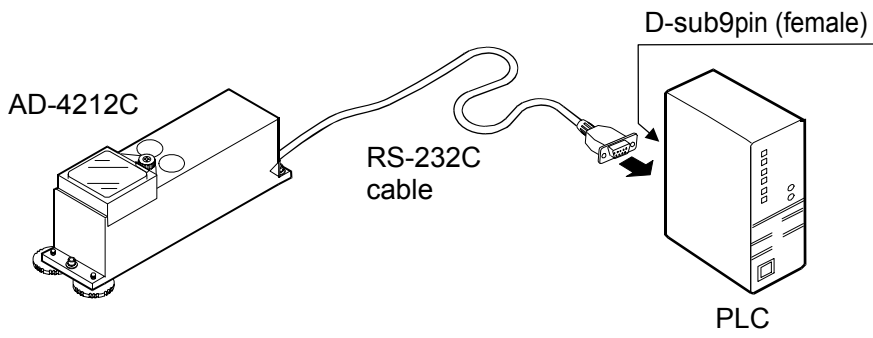

1.2. Compliance

Compliance with FCC Rules

Please note that this equipment generates, uses and can radiate radio frequency energy. This equipment has been tested and has been found to comply with the limits of a Class A computing device pursuant to Subpart J of Part 15 of FCC rules. These rules are designed to provide reasonable protection against interference when the equipment is operated in a commercial environment. If this unit is operated in a residential area, it may cause some interference and under these circumstances the user would be required to take, at his own expense, whatever measures are necessary to eliminate the interference.

(FCC = Federal Communications Commission in the U.S.A.)

Compliance with EMC Directives



This device features radio interference suppression in compliance with valid EC Regulation 89/336/EEC.

2. UNPACKING THE BALANCE

2.1. Unpacking

- The balance is a precision instrument. Unpack the balance carefully. Keep the packing material to be used for transporting the balance in the future.
- Each of the AD-4212C series may have different packing contents depending on the model. Therefore, see the illustrations to confirm that everything is contained.

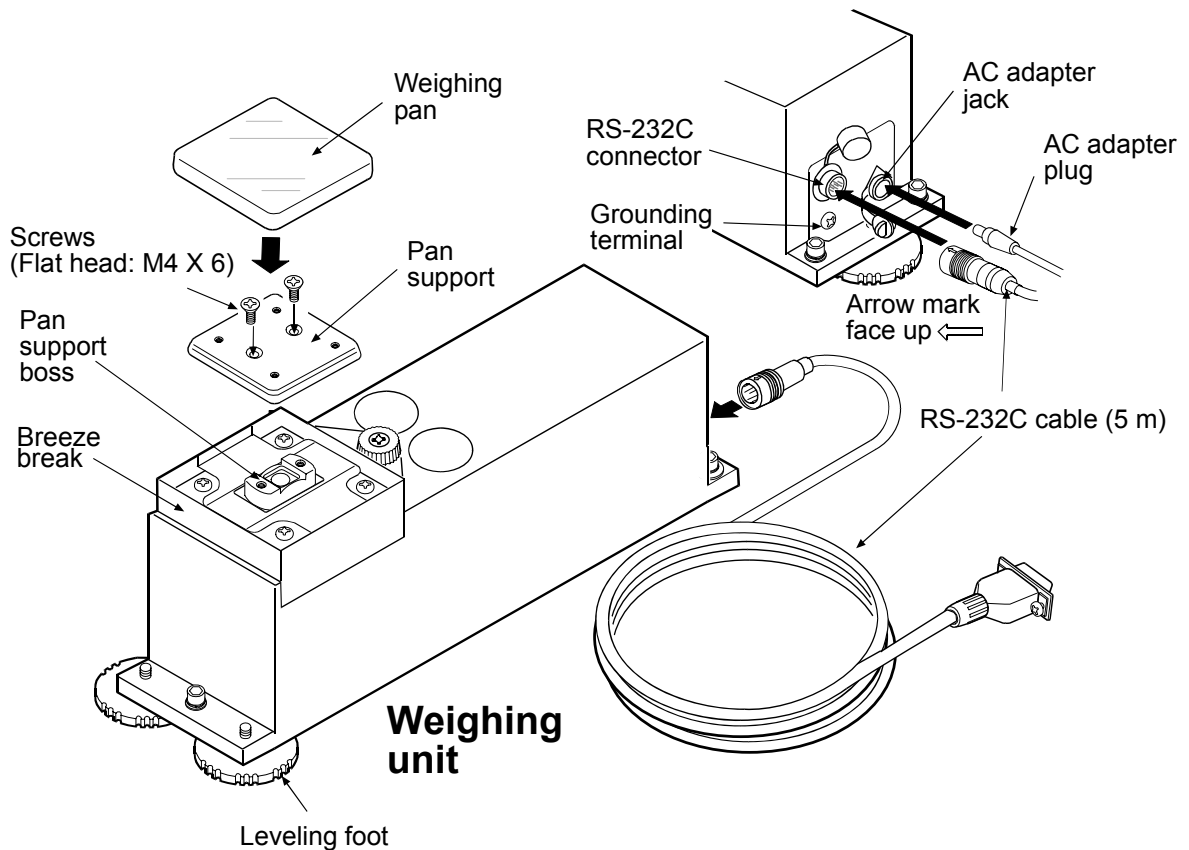

Accessories

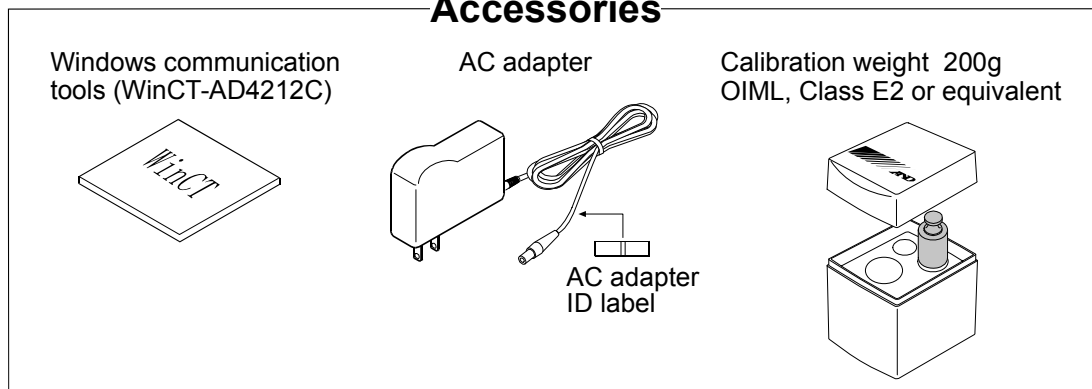

Notes

- Please confirm that the AC adapter type is correct for your local voltage and receptacle type.

ATTACHING THE AD-4212C SERIES WEIGHING UNIT DIRECTLY ON THE MOUNTING BASE

When the AD-4212C series weighing unit is built into a system, remove the three leveling feet and use the screw holes when mounting the weighing unit.

Attachment Procedure

1. Remove the three leveling feet.

Caution

Removing any other screws from the bottom of the weighing unit could damage the weighing sensor.

2. Secure the weighing unit from above.
(Prepare appropriate screws with a size corresponding to the M5 screw. The screw hole diameter: 6 mm)
In case of securing the weighing unit from the under side, use the screws holes of the leveling foot. (M6 screw x pitch 1 mm)

Notes

- The screws to secure the weighing unit to the weighing platform are not provided.
- Refer to "9 EXTERNAL DIMENSIONS", to determine the position of the holes for securing the weighing unit.

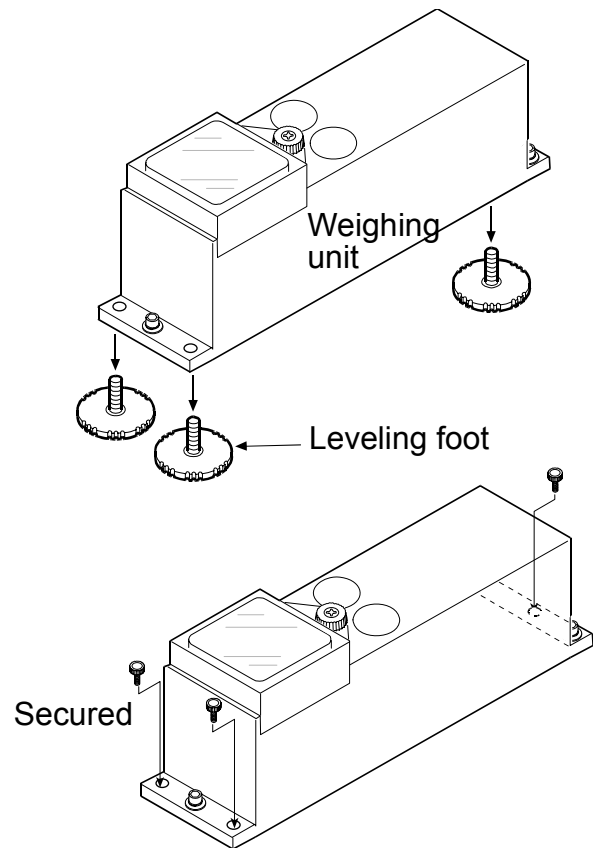

When the leveling adjustment is difficult to perform due to the installation conditions, place a shim between the lower surface of the weighing unit and the securing surface, or use two nuts. If the adjustment is still difficult to perform, perform calibration before use. Then, the balance will function normally.

2.2. Installing the Balance

Install the balance as follows:

1. Refer to "3. PRECAUTIONS" for installing the balance.
2. Refer to "2-1 Unpacking" on the previous page, to attach the pan support and the weighing pan on the weighing unit.
3. Insert the RS-232C cable into the jack located on the rear of the weighing unit.

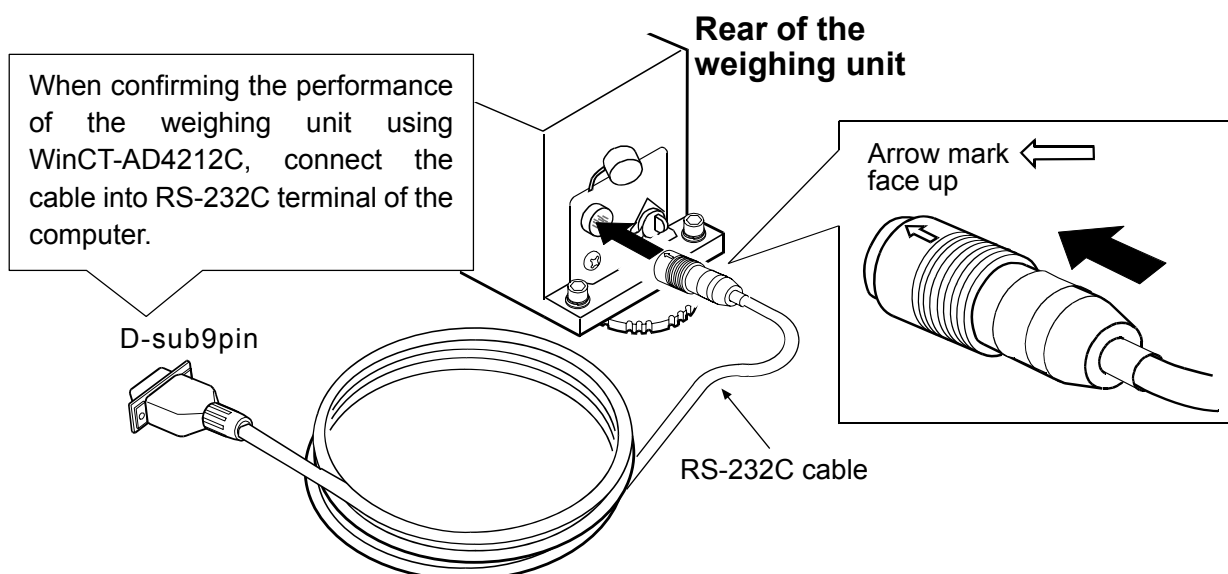

How to disconnect the cable from the weighing unit

Slide the connector sleeve in the direction of the arrow to unlock and gently pull the connector out.

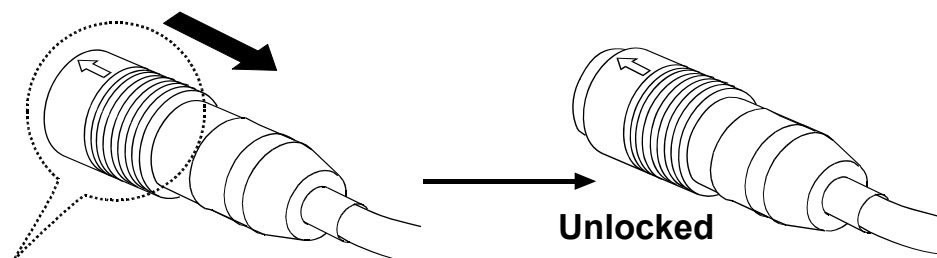

Slide the connector sleeve in the direction of the arrow

4. Confirm that the adapter type is correct for the local voltage and power receptacle type.
5. Plug the AC adapter plug into the AC adapter jack located on the rear of the weighing unit and plug the AC adapter into the electrical outlet. Warm up the balance for 30 minutes or more with nothing on the weighing pan.
6. Set the pan unit and I/O unit to adapt to the peripheral system. Set the following for the I/O unit.
 - RS-232C (Refer to "5.COMUNICATIOM SPECIFICATIONS")

Set the weighing speed to adapt to the ambient conditions.

7. After the balance has been installed, calibrate the balance using the calibration weight provided with the balance (The AD-4212C-3000 can be calibrated using the 200g weight). For details, refer to "4.2. Calibration".
8. By removing the provided weighing pan, a locally fabricated weighing pan can be attached to the AD-4212C series by using the four screws hole (M4 screw x pitch 0.7 mm) on the pan support.

3. PRECAUTIONS

To get the optimum performance from the balance and acquire accurate weighing data, note the following:

3.1. Before Use

- Install the weighing unit in an environment where the temperature and humidity are not excessive. The best operating temperature is about 20°C / 68°F at about 50% relative humidity.
- Install the weighing unit where it is not exposed to direct sunlight and it is not affected by heaters or air conditioners.
- Install the weighing unit where it is free of dust.
- Install the weighing unit away from equipment which produces magnetic fields.
- Install the weighing unit in a stable place avoiding vibration and shock. Corners of rooms on the first floor are best, as they are less prone to vibration.
- Ensure a stable power source when using the AC adapter.
- Warm up the balance for 30 minutes or more. Plug in the AC adapter as usual.
- Calibrate the balance before use or after having moved it to another location.

In addition, calibrate it periodically to maintain the accuracy.

Caution

Do not install the balance where flammable or corrosive gas is present.

3.2. When Building Into a System

The AD-4212C is a precision balance. When it is built into a system and used, errors such as unstable weight values may occur due to static electricity, vibration and materials used for the devices near the balance.

When using the balance that is built into a system, take the following precautions.

- Errors due to a static charge

When the ambient humidity is less than 45% RH, insulators such as plastic or glass are prone to static electricity. When charged material comes close to the balance, a pulling force is generated between the charged material and the weighing pan. This causes an unstable weight value.

To protect the balance against a discharge generated by charged material when it comes close to the balance, make sure to earth ground the weighing unit and the display unit.

(Static electricity generated by static induction will not be canceled by earth-grounding.)

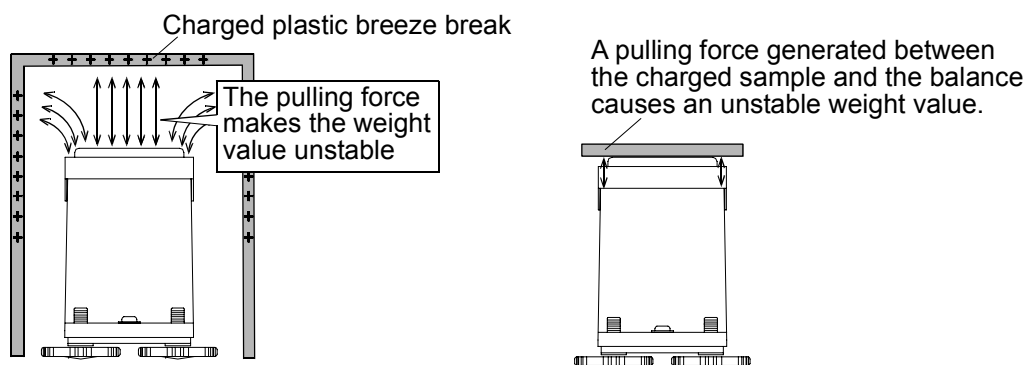

Measures to take (Plastic is used in the measures below. They can be applied to glass, too.)

- When the sample or devices are plastic
 - Use a static eliminator that generates no air blow such as the AD-1683, DC static eliminator, to remove static electricity.
 - Place the sample in a container that is made of a conductive material such as metal and that can be sealed and weigh it.
- When the sample is powdery
 - When the balance is used in combination with a feeder for batch weighing of powdery samples, samples may be charged by rubbing sample particles against each other. Use a static eliminator and perform weighing while removing static electricity.
- When the sample container is made of material that is prone to static electricity such as plastic
 - Cover the outside of the container with a metal such as aluminum foil.
 - Apply an anti-static agent onto the container.
- When making a breeze break using plastic
 - Apply an anti-static agent onto the breeze break.
 - Use a conductive acrylic fiber.
- When plastic exists in the balance installation site
 - Cover the plastic with a grounded metal.
 - Apply an anti-static agent onto plastic.
- When an operator is static charged

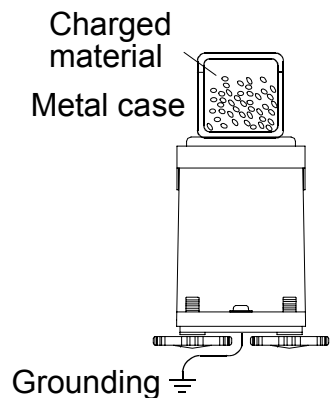

If an operator's clothes are static charged, especially in winter, it may be a cause for unstable weight values.

- Wear an anti-static wrist strap.

● Errors due to air flow

- Where the influence of ambient air flow is great such as: close to an air conditioner, door or passage way. Even very subtle air flow that is hard to be detected may influence the weighing operation.

- Avoid those areas as a weighing site.
- If weighing is to be performed in such an area, use a breeze break or take other appropriate measures.

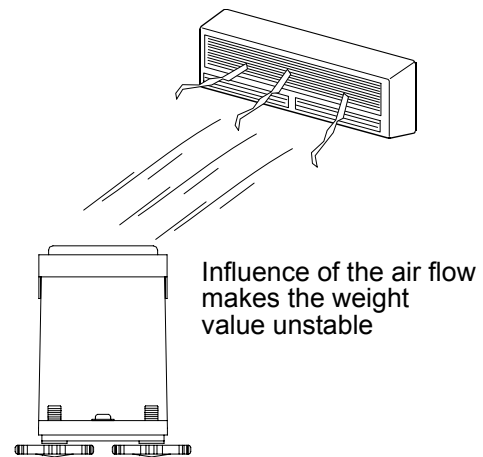

- Where the influence of heat or drafts is great

- Eliminate temperature differences between a sample and the environment. When a sample is warmer (cooler) than the ambient temperature, the sample will be lighter (heavier) than the true weight. This error is due to a rising (falling) draft around the sample.

- Do not touch the sample directly with your hand. Use tweezers or other tools. If you touch the sample, the same type error described above will occur.

- Do not perform weighing where it is exposed to direct sunlight. Weighing errors may occur due to sudden temperature change or drafts.

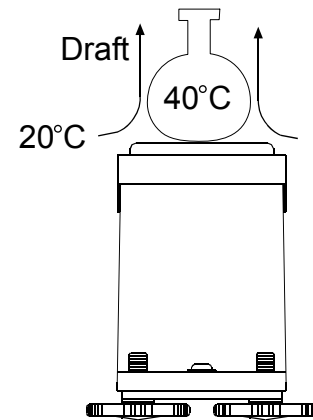

- Where the influence of vibration is great, such as:

(1) Soft ground (2) Second or higher floor (3) Near center of a floor far from pillars (4) Seismic isolated structures (5) Near tall buildings.

In the areas listed above, the scale may yield unstable weight values on windy days or after an earthquake. Especially in case of (4) and (5), weight values may be unstable during and for a long period of time after strong winds or an earthquake.

● Errors due to other causes

- Change in temperature or humidity

A sudden change in temperature or humidity can generate a draft and cause the balance to absorb or exude moisture, which leads to weighing errors.

- Avoid sudden change in temperature or humidity.
- Use an air conditioner to control the temperature or humidity.

- Magnetic material

The balance uses a strong magnet as part of the balance assembly, so use much care when weighing magnetic materials.

- Place a non-magnetic object such as aluminum or brass between the sample and the balance, also keep an appropriate distance between them while weighing.

3.3. During Use

- To minimize the affect by electrical noises, earth ground the weighing unit and the display unit (option).
- Do not drop things upon the weighing pan, or place a sample on the pan that is beyond the balance weighing capacity. Place a sample in the center of the weighing pan.
- Do not use a sharp instrument such as a pencil to press the buttons. Use your finger only.
- Before each weighing to prevent possible errors, perform the zero resetting by the RS-232C command, or calculate the weighing value from the difference between the weighing before and after.
- Take into consideration the affect of air buoyancy on a sample when more accuracy is required.
- Keep the balance interior free of dust and foreign materials.

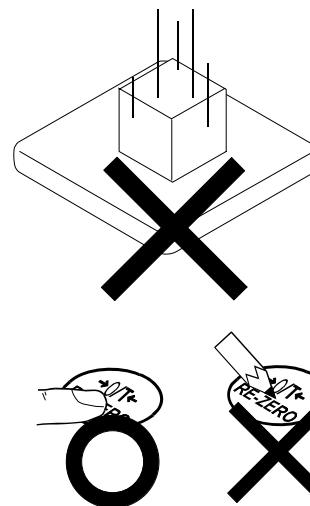

3.4. After Use

- Avoid mechanical shock to the weighing unit.
- Calibrate the balance, using a calibration weight, periodically.
- Do not disassemble the weighing unit. Contact the local A&D dealer if the balance needs service or repair.
- Do not use organic solvents to clean the weighing unit. Clean the weighing unit with a lint free cloth that is moistened with warm water and a mild detergent.
- Avoid dust and water so that the weighing unit weighs correctly. Protect the internal parts from liquid spills and excessive dust.

3.5. Power Supply

- When the AC adapter is connected, the balance is in the standby mode if the standby indicator is on (refer to “4. OPERATION OF WinCT-AD4212C”). This is a normal state and does not harm the balance. For accurate weighing, plug in the AC adapter and warm up the balance for the appropriate duration before use.

4. OPERATION OF WinCT-AD4212C

The software has the functions as follows:

- Set the weighing speed of the weighing unit
- Set the minimum display value
- Calibration

The AD-4212C series can store the weighing data. Therefore it can confirm the weighing data after weighing.

* These parameters stored, even if the AC adapter is removed, are maintained in non-volatile memory.

Before use

1. Install the WinCT-AD4212C into the computer. For detail, refer to Readme of WinCT-AD4212C.
2. Connect one end of the D-sub 9pin cable to the weighing unit RS-232C connector and connect the other end of the D-sub 9pin cable to the personal computer RS-232C terminal.
3. Set the COM port of the WinCT-AD4212C on the personal computer, and press the **START** button. The personal computer will display the weighing value.

Function of display symbols and button

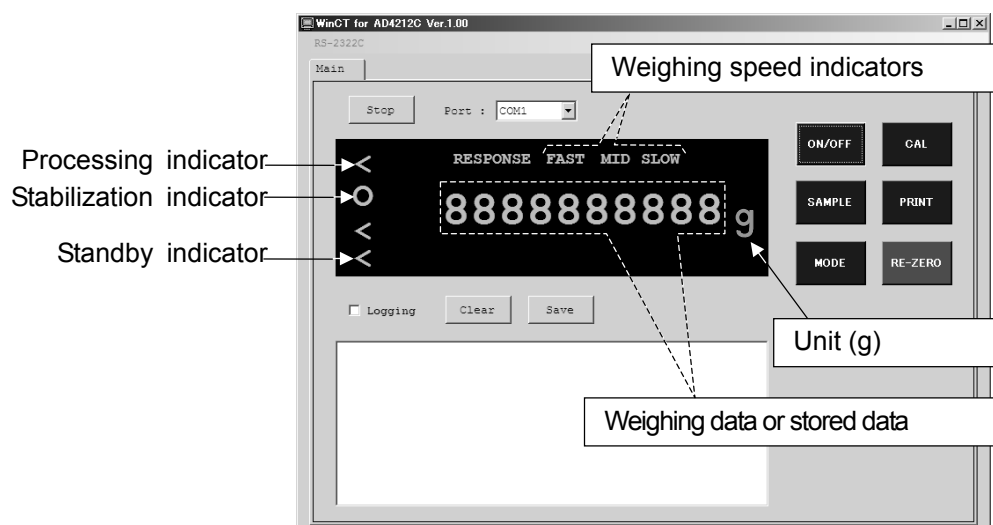

| Button | When pressed |
|----------------|--|
| ON/OFF | Switches between the weighing mode and the standby mode. With the standby mode, only the standby indicator is displayed. The ON/OFF button is available anytime. Therefore, if you press the ON/OFF button when operating, the balance switches to the standby mode. |
| SAMPLE | In the weighing mode, switches the minimum weighing value. |
| MODE | Changes weighing speed. |
| CAL | Enters the calibration mode. |
| PRINT | (Usually no function. Use the calibration mode.) |
| RE-ZERO | Sets the display to zero. |

4.1. Changing the Weighing Speed Using WinCT-AD4212C

The weighing speed can be selected from the following three rates to minimize the influence on weighing that is caused by drafts and/or vibration at the place where the balance is installed.

| Indicator | Speed | Stability |
|-----------|-------|-----------------|
| FAST | Fast | Sensitive value |
| MID. | ↑ | ↓ |
| SLOW | Slow | Stable value |

Weighing speed setting

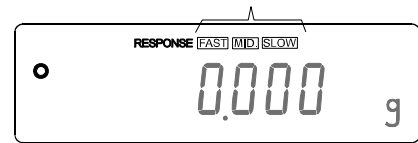

Operation

1. Press the **MODE** button.

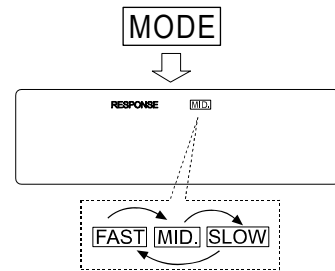

2. Press the **MODE** button to select a weighing speed.
Either **FAST**, **MID.** or **SLOW** can be selected.

MODE Each pressing switches the indicators

4.2. Calibration

Calibration

Calibration using the calibration weight.

Caution

- Do not allow vibration or drafts to affect the balance during calibration.

Caution on using an external calibration weight

- The accuracy of the weight can influence the accuracy of weighing. Select an appropriate weight as listed below. A calibration weight (conforming to OIML, Class E2 or equivalent) is provided with the balance as a standard accessory.

| Model | Usable calibration weight | Calibration weight provided |
|---------------|-----------------------------|-----------------------------|
| AD-4212C-300 | 100g, 200 g , 300g | 200 g |
| AD-4212C-3000 | 200 g , 2000g, 3000g | |

The calibration weight in bold type: factory setting

Display



- This indicator means “the balance is measuring calibration data”. Do not allow vibration or drafts to affect the balance while this indicator is displayed.

Calibration procedure

This function calibrates the balance using the calibration weight. (Display example: AD-4212C-300)

Operation

1. Plug in the AC adapter and warm up the balance for 30 minutes or more with nothing on the pan.

2. Press the **CAL** button. **CAL 0** is displayed.

- If you want to cancel calibration, press the **CAL** button. The balance will return to the weighing mode.
- If you want to change the calibration mass value, press the **SAMPLE** button. Press the **RE-ZERO** button to select the mass value, and press the **PRINT** button to store. **CAL 0** is displayed.

3. Confirm that there is nothing on the pan and press the **PRINT** button. The balance measures the zero point. Do not allow vibration or drafts to affect the balance.
The balance displays the calibration weight value.

4. Place a calibration weight, of the weight value displayed, on the pan and press the **PRINT** button. The balance measures the calibration weight. Do not allow vibration or drafts to affect the balance.

5. The balance displays **End**. Remove the weight from the pan.

6. The balance will automatically return to the weighing mode.

7. Place the calibration weight on the pan and confirm that calibration was performed correctly. If not, check the ambient conditions such as drafts or vibration, and repeat steps 2 through 7.

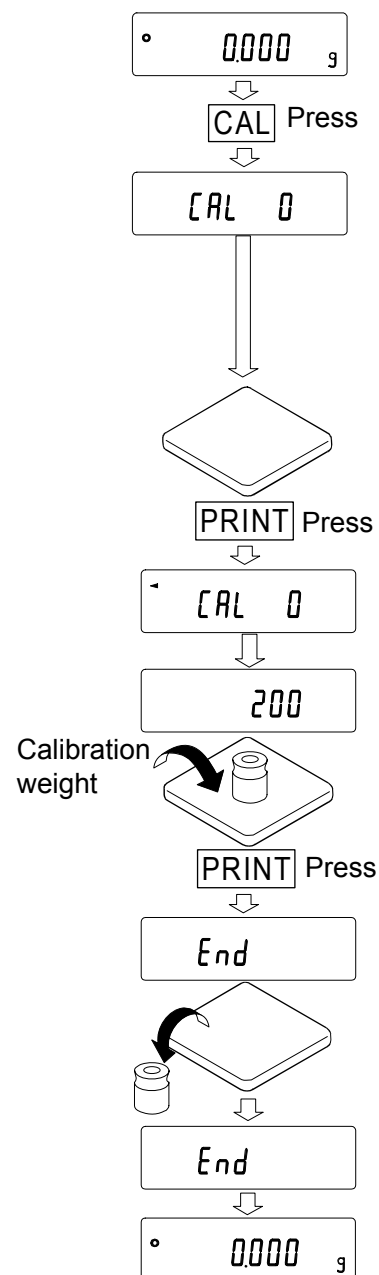

5. COMMUNICATION SPECIFICATIONS

The AD-4212C series can communicate interactively using RS-232C.

The AD-4212C series can continuously forward the weighing data. (Approx.10 times/second* to 50 times/second)

The AD-4212C series is DCE. The AD-4212C series can connect directly into the RS-232C connector of a personal computer by using the provided RS-232C cable.

* Factory setting

1. RS-232C specification

| | | |
|---------------------|--|----------------------|
| Transmission system | EIA RS-232C | |
| Transmission form | Asynchronous, bi-directional, half duplex | |
| Transmission rate | Approx.10 times/second* to 50 times/second | |
| Data format | Baud rate | 2400bps* to 19200bps |
| | Data bits | 7 bits |
| | Parity | EVEN |
| | Stop bit | 1 bits |
| | Code | ASCII |
| | Terminator | <CR><LF> |

* Factory setting

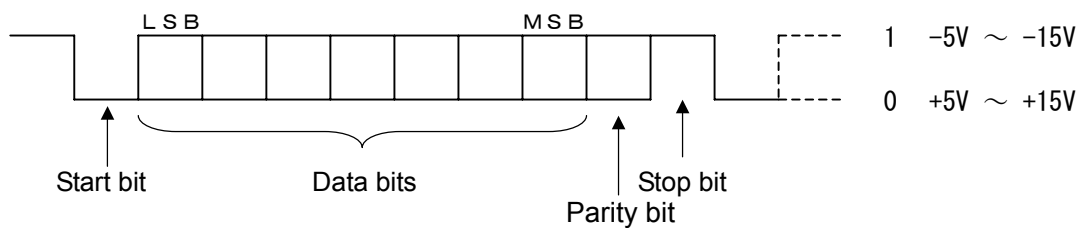

Relation between baud rate and transmission rate of weighing value

| Baud rate | Transmission rate of weighing value |
|-----------|-------------------------------------|
| 2400bps | 12.5 times/second |
| 4800bps | 25 times/second |
| 9600bps | 50 times/second |
| 19200bps | 50 times/second |

2. Pin position

Pin position of the RS-232C communication cable (D-Sub9pin side female)

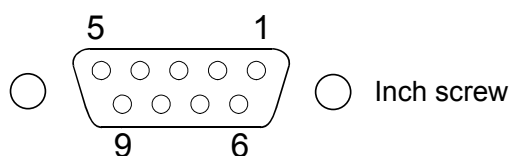

| Pin No. | Signal name | Direction | Description |
|---------|-------------|-----------|---|
| 1 | (Vs) | - | Internally used * (Power supply GND terminal for external equipment) |
| 2 | TXD | Output | Transmit data |
| 3 | RXD | Input | Receive data |
| 4 | - | - | N.C. |
| 5 | SG | - | Signal ground |
| 6 | - | - | Internally used * |
| 7 | RTS | Input | Request to send |
| 8 | CTS | Output | Permission to send |
| 9 | (Va) | - | Internally used * (Power supply output terminal for external equipment) |

CTS and RTS are internally connected in the balance.

The AD-4212C can communicate by connecting TXD and RXD to SG.

* When connecting to a PLC etc. as the external equipment, do not connect to the internally used signal line.

3. Data output format

- This format consists of fifteen characters excluding the terminator<CR><LF>.
- A header of two characters indicates the balance condition.
- The polarity sign is placed before the data with the leading zeros. If the data is zero, the plus sign is applied.

Example of output

| | | | | | | | | | | | | | | |
|--------|---|---|------|---|---|---|---|---|----|----|----|------|----|----|
| 1 | 2 | 3 | 4 | 5 | 6 | 7 | 8 | 9 | 10 | 11 | 12 | 13 | 14 | 15 |
| S | T | , | + | 0 | 0 | 1 | 2 | . | 3 | 4 | 5 | | | g |
| Header | | | Data | | | | | | | | | Unit | | |

When stable

| | | | | | | | | | | | | | | |
|---|---|---|---|---|---|---|---|---|---|---|---|--|--|---|
| S | T | , | + | 0 | 0 | 1 | 2 | . | 3 | 4 | 5 | | | g |
|---|---|---|---|---|---|---|---|---|---|---|---|--|--|---|

When unstable

| | | | | | | | | | | | | | | |
|---|---|---|---|---|---|---|---|---|---|---|---|--|--|---|
| U | S | , | + | 0 | 0 | 0 | 5 | . | 4 | 3 | 2 | | | g |
|---|---|---|---|---|---|---|---|---|---|---|---|--|--|---|

When over state (plus over)

| | | | | | | | | | | | | | | |
|---|---|---|---|---|---|---|---|---|---|---|---|---|---|---|
| O | L | , | + | 9 | 9 | 9 | 9 | 9 | 9 | 9 | E | + | 1 | 9 |
|---|---|---|---|---|---|---|---|---|---|---|---|---|---|---|

When over state (minus over)

| | | | | | | | | | | | | | | |
|---|---|---|---|---|---|---|---|---|---|---|---|---|---|---|
| O | L | , | - | 9 | 9 | 9 | 9 | 9 | 9 | 9 | E | + | 1 | 9 |
|---|---|---|---|---|---|---|---|---|---|---|---|---|---|---|

4. Command

When outputting the weighing data, the balance can be controlled by the following commands.

The balance command excluding the terminator<CR><LF>.

| Command | Description |
|------------|---|
| C | Stops the continuous output of the weighing data. |
| Q | Requests the weighing data immediately. (Outputs the stable or unstable weighing data usually. Used by the balance for stopping the continuous output.) |
| S | Requests the weighing data when stabilized. (After the weighing data has stabilized, outputs the data. Used by the balance for stopping the continuous output.) |
| SIR | Requests the weighing data continuously. Starts the continuous output of the weighing data. (The C command stops the continuous output.) |
| CAL | (Enters the calibration mode.) |
| OFF | Turns the display off. The weighing unit is in the standby mode. |
| ON | Turns the display on. The weighing unit is in the weighing mode. |
| P | Switches between the weighing mode and the standby mode. |
| PRT | (Used with the calibration mode.) |
| R | This command performs the weighing value zero (tare). ^{*1} |
| SMP | This command changes the minimum display. |
| U | This command changes the weighing speed. ^{*2} |

*1 When performing the weighing value zero, the command waits for the weighing value to become stable.

When the command waits for the weighing value to become stable, the balance stop sending weighing data.

*2 When changing the weighing speed, the balance outputs "@", then the control character "U".

The command to control the weighing data

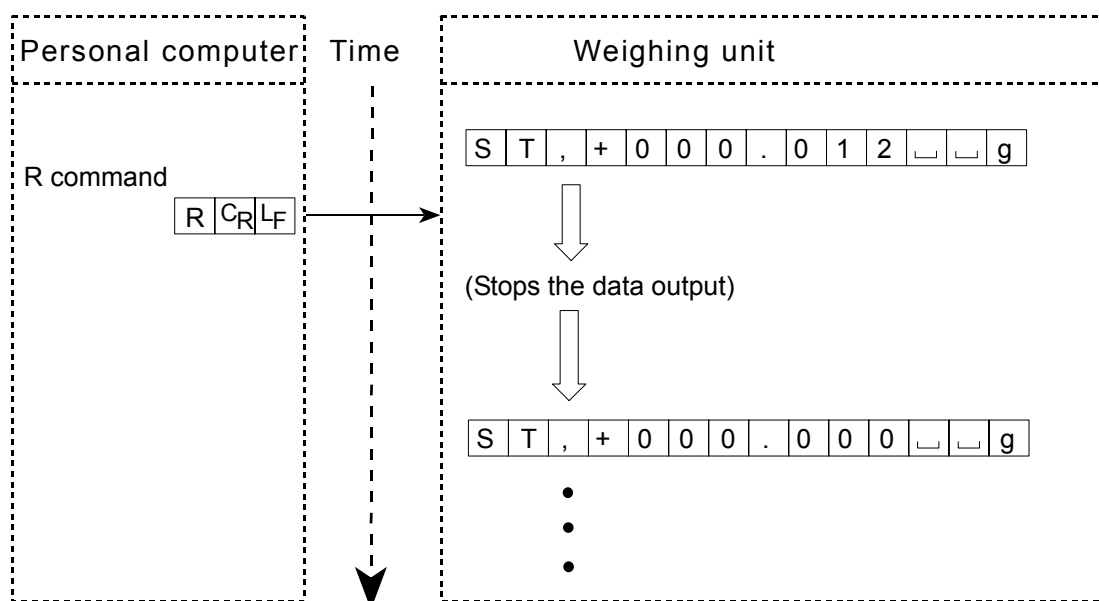

6. MAINTENANCE

- Do not disassemble the balance. Contact the local A&D dealer if the balance needs service or repair.
- Use the original packing material for transportation.
- Do not use organic solvents to clean the balance. Clean the balance with a lint free cloth that is moistened with warm water and a mild detergent.

7. TROUBLESHOOTING

7.1. Checking the Balance Performance and Environment

The balance is a precision instrument. When the operating environment or the operating method is inadequate, correct weighing can not be performed. Place a sample on the pan and remove it, and repeat this several times. If the balance seems to have a problem with repeatability or to perform improperly, check as described below. If improper performance persists after checking, contact the local A&D dealer for repair.

Checking that the balance performs properly

- Check the balance repeatability using the calibration weight. Be sure to place the weight in the center of the weighing pan. Pay attention to the air flow and be sure to use the breeze break.
- Check the balance repeatability, linearity and calibrated value using external weights with a known value.
- When the balance is built into a system, remove the balance from the system. Place it on a solid table. Install the breeze break and perform checking.
When the balance proper performance is confirmed, refer to page 8 to set up the installation site.

Checking that the operating environment or weighing method is proper

Operating environment

- Is the weighing table solid enough
- Is the balance level? Refer to page 6.
- Is the operating environment free from vibration and drafts? Has the stainless steel breeze break been installed?
- Is there a strong electrical or magnetic noise source such as a motor near the balance?
- Is there a heat source near the balance?

Weighing method

- Does the weighing pan touch the breeze break or anything? Is the weighing pan installed correctly?
- Has the weighing value been set to zero by using an RS-232C command (R command) before placing a sample on the weighing pan?

- Is the sample placed in the center of the weighing pan?
- Has the balance been warmed up for 30 minutes or more before weighing?
- Are the leveling feet of the weighing unit placed flat to the installation surface?

If not, the weight value will be unstable or the specified repeatability can not be obtained.

Improve the installation condition, by securing the weighing unit or reducing the vibration that is conveyed to the weighing unit.

Sample and container

- Has the sample absorbed or lost moisture due to the ambient conditions such as temperature or humidity?
- Has the temperature of the container been allowed to equalize to the ambient temperature? Refer to “3-2 When Building into a System”.
- Is the sample charged with static electricity? Refer to “3-2 When Building into a System”.
- Is the sample of magnetic material such as iron? Use much care when weighing magnetic materials. Refer to “3-2 When Building into a System”.

7.2. Asking For Repair

If the balance needs service or repair, contact the local A&D dealer.

The balance is a precision instrument. Use much care when handling the balance and observe the following when transporting the balance.

- Use the original packing material.
- Remove the weighing pan from the weighing unit.

8. SPECIFICATIONS

| | | AD-4212C-300 | | AD-4212C-3000 | |
|---|--------------|---|------------|--------------------|------------|
| Weighing capacity | | 320g | | 3200g | |
| Maximum display | | 320.084g | | 3200.84g | |
| Minimum weighing value (1 digit) | | 0.001g | | 0.01g | |
| Repeatability (Standard deviation) | | 0.001g | | 0.01g | |
| Linearity | | ±0.002g | | ±0.02g | |
| Stabilization time in seconds (typical at FAST under good environment) | | 0 - 30g | 0.5 second | 0 - 30g | 0.5 second |
| | | 30 - 320g | 1.0 second | 30 - 3200g | 1.0 second |
| Display refresh rate | | Approx.10 times/second* to 50 times/second | | | |
| I/O unit | RS-232C | Bi-directional, 2400 bps* to 19200 bps (WinCT-AD4212C communication software provided) | | | |
| Sensitivity drift | | ±2 ppm/°C (10°C to 30°C/50°F to 86°F) | | | |
| Operating environment | | 5°C to 40°C (41°F to 104°F), 85% RH or less (No condensation) | | | |
| Calibration weight provided (Conforming to OIML Class E2) | | 200g | | 200g | |
| Applicable weight values | | 100g, 200g, 300g | | 200g, 2000g, 3000g | |
| Weighing unit | Dimensions | 59 (W) × 231 (D) × 91 (H) mm | | | |
| | Weighing pan | 50 × 50 mm | | | |
| | Mass | Approx. 1.6kg | | | |
| Connection cable | | Approx. 5 m | | | |
| Unit display mode | | g | | | |
| AC adapter | | Output voltage 12V (Confirm that the adapter type is correct for the local voltage and power receptacle type) | | | |
| Power consumption | | Approx. 11VA (supplied to the AC adapter) | | | |

* Factory setting

9. EXTERNAL DIMENSIONS

- AD-4212C-300 / AD-4212C-3000

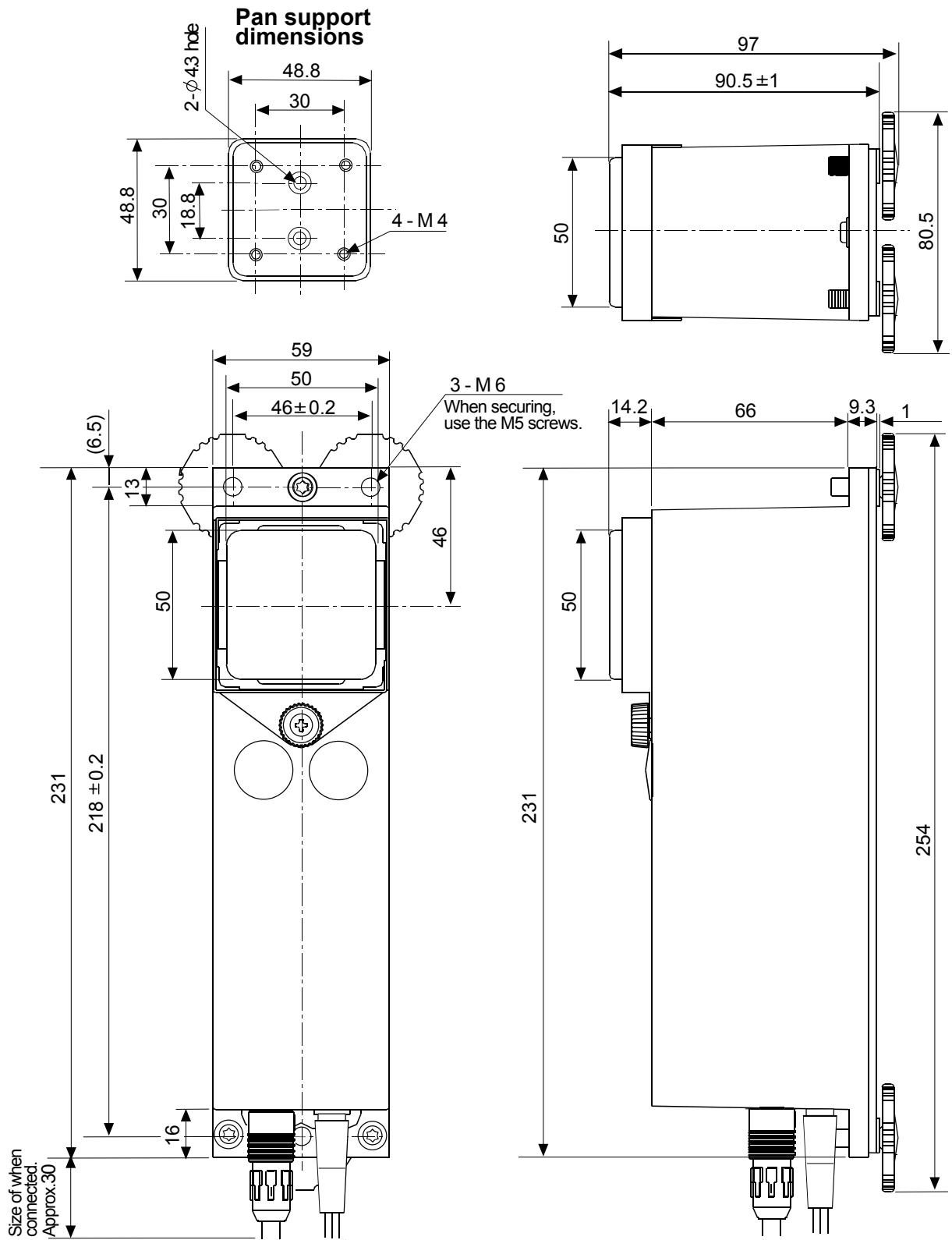

Unit: mm

10. OPTIONS

AX-USB-9P: USB converter/Cable set

- USB converter (D-Sub9pin - USB)
 - RS-232C cable (D-Sub9pin - D-Sub9pin)
- * This RS-232C cable is not used with the AD-4212C series.

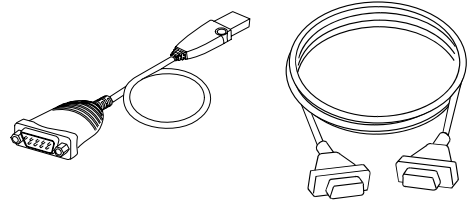

AD-8922A: Remote controller

- The AD-8922A can perform the taking of weighing data, re-zero and calibration manually.
- The AD-8922A can output data using BCD, comparator or analog out by selection of the option installed in the AD-8922A.

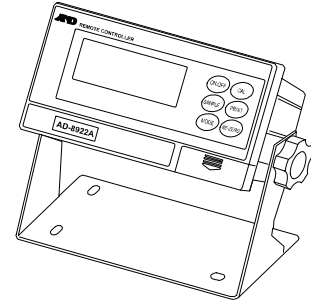

AD-8526: Ethernet converter

- When connected to an AD-8526, it can convert RS-232C output data to a LAN.

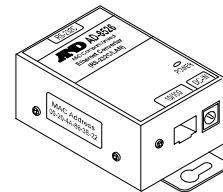

AD-1683: DC static eliminator

- A compact design with efficient static elimination
- No air blowing from a fan allows precision weighing

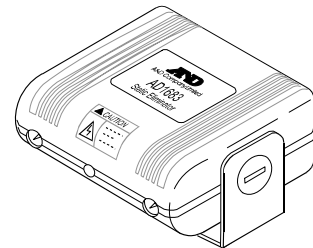

AD-1684: Electrostatic field meter

- This option measures the amount of the static charge on the sample, tare or peripheral equipment and displays the result.
- If those are found to be charged, discharge them using the AD-1683 DC static eliminator.

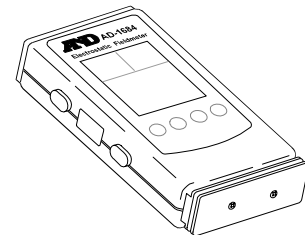

AD-8121B Printer

- Compact thermal dot-matrix printer
- Statistical function, clock and calendar function, interval print function, graphic print function, dump print mode
- 5 x 7 dots, 16 characters per line
- Print paper (AX-PP143, 45 (W) x 50 (L) mm , ø65 mm)
- AC adapter or alkaline battery

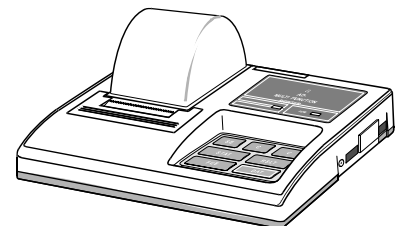





11. TERMS/INDEX

Terms

| | |
|---------------------------|--|
| Stable value | The weight data when the stabilization indicator appears. |
| Environment | Ambient conditions such as vibration, drafts, temperature, static electricity or magnetic fields which affect the weighing operation. |
| Calibration | Adjustment of the balance so that it can weigh accurately. |
| Output | To output the weighing data using the RS-232C interface. |
| Zero point | A weighing reference point or the zero display. Usually refers to the value displayed when nothing is on the weighing pan. |
| Digit | Unit of digital resolution. Used for the balance, the minimum displayable weighing value. |
| Tare | To cancel the weight of a container which is not included in the weighing data. |
| Mode | Balance operational function. |
| Re-zero | To set the display to zero. |
| GLP | Good Laboratory Practice. |
| Repeatability | Variation in measured values obtained when the same weight is placed and removed repetitively. Usually expressed as a standard deviation. e.g. Standard deviation=1 digit: This means that measured values fall within ± 1 digit in the frequency of about 68%. |
| Stabilization time | Time required after a sample being placed, until the stabilization indicator illuminates and the weighing data is displayed. |
| Sensitivity drift | An affect that a change in temperature causes to the weighing data. Expressed as temperature coefficient. e.g. Temperature coefficient = 2 ppm/ $^{\circ}$ C : If a load is 100 g and the temperature changes by 10 $^{\circ}$ C, the value displayed changes by the following value. $0.0002\%/^{\circ}$ C x 10 $^{\circ}$ C x 100 g = 2 mg |

Index

Symbols

| | | |
|---|--------------------------------|----|
| C_R | Carriage return | 18 |
| L_F | Line feed..... | 18 |
| □ | space mark..... | 18 |
|  | Processing indicator | 12 |
|  | Stabilization indicator | 12 |
|  | Standby indicator..... | 12 |
|  | Weighing speed indicators..... | 12 |

A

| | |
|------------------------------|-------------|
| AC adapter | 5, 7, 8, 11 |
| AD-1683 | 9, 23 |
| AD-1684 | 23 |
| AD-8121B..... | 23 |
| AD-8526 | 3, 23 |
| AD-8922A..... | 2, 3, 23 |
| Ambient humidity | 9 |
| Anti-static agent..... | 9 |
| Anti-static wrist strap..... | 10 |
| AX-USB-9P..... | 23 |

B

| | |
|--------------------|---|
| BCD..... | 3 |
| Breeze break | 5 |

C

| | |
|--|----------------------|
| C command | 18 |
| Cable set | 23 |
|  button | 12, 15 |
| CAL command..... | 18 |
| Calibration | 11, 14, 15, 24 |
| Calibration weight..... | 5, 7, 14, 15, 19, 21 |
| Charged material | 9 |
| Conductive acrylic fiber | 9 |
| Connect | 2, 3 |

D

| | |
|-------------|----|
| Digit | 24 |
|-------------|----|

| | |
|---------------------------|----|
| Discharge..... | 9 |
| Display refresh rate..... | 21 |

E

| | |
|--------------------|---|
| Earth ground | 9 |
|--------------------|---|

F

| | |
|---|-----------|
|  | 2, 13, 21 |
|---|-----------|

G

| | |
|--------------------------|---|
| Grounding terminal | 5 |
|--------------------------|---|



I

| | |
|------------------|----|
| I/O unit | 21 |
| Insulators | 9 |

L

| | |
|---------------------|------|
| LAN..... | 3 |
| Leveling foot | 5, 6 |
| Linearity | 21 |

M

| | |
|---|-------|
| Maximum display | 21 |
|  | 13 |
| Minimum weighing value..... | 2, 21 |
|  button..... | 12 |

O

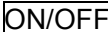
| | |
|--|----|
| OFF command..... | 18 |
|  button | 12 |
| ON command..... | 18 |
| Operating environment | 21 |

P

| | |
|-----------------------|----|
| P command..... | 18 |
| Pan support | 5 |
| Pan support boss..... | 5 |

| | | | |
|-----------------------------|----------|--------------------------|-----------|
| Personal computer | 2 | Stabilization time | 2, 21, 24 |
| Plastic | 9 | Stable value | 13, 24 |
| PLC | 3 | Static charge | 9, 10 |
| Powdery samples | 9 | Static electricity | 9 |
| PRINT button | 12 | Static electricity | 20, 24 |
| PRT command | 18 | | |
| | | U | |
| Q | | U command | 18 |
| Q command | 18 | Units | 12, 21 |
| | | USB | 2 |
| R | | USB converter | 2, 23 |
| R command | 18 | | |
| Repeatability | 19 | V | |
| Repeatability | 21, 24 | Vibration | 9 |
| RE-ZERO button | 12 | | |
| RS-232C | 2, 3, 16 | W | |
| RS-232C cable | 5, 7 | Warm up | 7, 8, 11 |
| | | Weighing capacity | 2, 11, 21 |
| S | | Weighing pan | 5 |
| S command | 18 | Weighing speed | 7, 12, 13 |
| SAMPLE button | 12 | WinCT-AD4212C | 2, 5, 12 |
| Sensitivity drift | 21 | | |
| SIR command | 18 | Z | |
| SLOW | 13 | Zero point | 15 |
| SMP command | 18 | | |

